

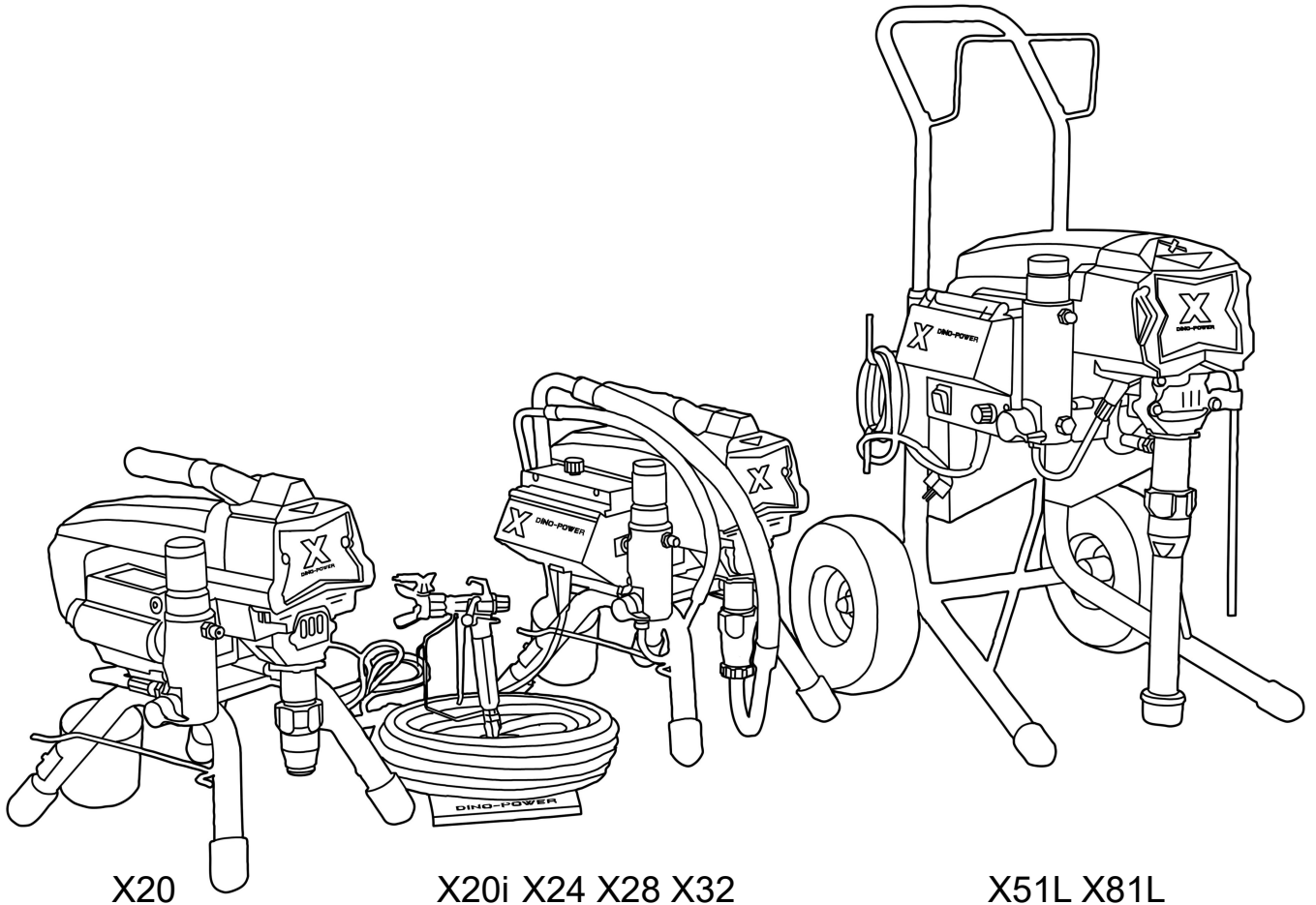

DINO-POWER

Operating Instruction

DP- X Series



Please read and keep this manual, Read carefully before attempting to assemble, install, operate or maintain the product described. Protect yourself and others by observing all safety information. Failure to comply with instructions could result in personal injury and/or property damage! Retain instruction for future reference.



FIRE AND EXPLOSION HAZARD

Flammable fumes, such as solvent and paint fumes, in work area can ignite or explode. To help prevent fire and explosion:

- Do not spray flammable or combustible materials near an open flame or sources of ignition such as cigarettes, motors, and electrical equipment.
 - Paint or solvent flowing through the equipment is able to result in static electricity. Static electricity creates a risk of fire or explosion in the presence of paint or solvent fumes. All parts of the spray system, including the pump, hose assembly, spray gun, and objects in and around the spray area shall be properly grounded to protect against static discharge and sparks. Use DINO-POWER conductive or grounded high-pressure airless paint sprayer hoses.
 - Verify that all containers and collection systems are grounded to prevent static discharge.
 - Connect to a grounded outlet and use grounded extensions cords. Do not use a 3-to-2 adapter.
 - Do not use a paint or a solvent containing halogenated hydrocarbons.
 - Keep spray area well-ventilated. Keep a good supply of fresh air moving through the area. Keep pump assembly in a well ventilated area. Do not spray pump assembly.
 - Do not smoke in the spray area.
 - Do not operate light switches, engines, or similar spark producing products in the spray area.
 - Keep area clean and free of paint or solvent containers, rags, and other flammable materials.
 - Know the contents of the paints and solvents being sprayed. Read all Material Safety Data Sheets (MSDS) and container labels provided with the paints and solvents. Follow the paint and solvents Manufacturer's safety instructions.
 - Fire extinguisher equipment shall be present and working
- Sprayer generates sparks. When flammable liquid is used in or near the sprayer or for flushing or
- Keep sprayer at least 20 feet (6 m) away from explosive vapors.



ELECTRIC SHOCK HAZARD

This equipment must be grounded. Improper grounding, set up, or usage of the system can cause electric shock.

- Turn off and disconnect power cord before servicing equipment.
- Use only grounded electrical outlets.
- Use only 3-wire extension cords.
- Ensure ground prongs are intact on power and extension cords.
- Do not expose to rain. Store indoors.

SKIN INJECTION HAZARD

High-pressure spray is able to inject toxins into the body and cause serious bodily injury. In the event that injection occurs, get immediate surgical treatment.

- Do not aim the gun at, or spray any person or animal.
- Keep hands and other body parts away from the discharge. For example, do not try to stop leaks with any part of the body.
- Always use the nozzle tip guard. Do not spray without nozzle tip guard in place.
- Use DP nozzle tips.
- Use caution when cleaning and changing nozzle tips. In the case where the nozzle tip clogs while spraying, follow the Pressure Relief Procedure for turning off the unit and relieving the pressure before removing the nozzle tip to clean.
- Do not leave the unit energized or under pressure while unattended. When the unit is not in use, turn off the unit and follow the Pressure Relief Procedure for turning off the unit
- Check hoses and parts for signs of damage. Replace any damaged hoses or parts.
- This system is capable of producing 3630 psi. Use DP replacement parts or accessories that are rated a minimum of 3000 psi





PRESSURIZED ALUMINUM PARTS HAZARD

Use of fluids that are incompatible with aluminum in pressurized equipment can cause serious chemical reaction and equipment rupture. Failure to follow this warning can result in death, serious injury, or property damage.

- Do not use 1,1,1-trichloroethane, methylene chloride, other halogenated hydrocarbon solvents or fluids containing such solvents.
- Many other fluids may contain chemicals that can react with aluminum. Contact your material supplier for compatibility.



EQUIPMENT MISUSE HAZARD

Misuse can cause death or serious injury.

- Always wear appropriate gloves, eye protection, and a respirator or mask when painting.
- Do not operate or spray near children. Keep children away from equipment at all times.
- Do not overreach or stand on an unstable support. Keep effective footing and balance at all times.
- Stay alert and watch what you are doing.
- Do not leave the unit energized or under pressure while unattended. When the unit is not in use, turn off the unit and follow the Pressure Relief Procedure for turning off the unit.
- Do not operate the unit when fatigued or under the influence of drugs or alcohol.
- Do not kink or over-bend the hose.
- Do not expose the hose to temperatures or to pressures in excess of those specified by us.
- Do not use the hose as a strength member to pull or lift the equipment.



MOVING PARTS HAZARD

Moving parts can pinch, cut or amputate fingers and other body parts.

- Keep clear of moving parts.
- Do not operate equipment with protective guards or covers removed.
- Pressurized equipment can start without warning. Before checking, moving, or servicing equipment, follow the Pressure Relief Procedure and disconnect all power sources.



BURN HAZARD

Equipment surfaces can become very hot during operation. To avoid severe burns, do not touch hot equipment. Wait until equipment has cooled completely.



TOXIC FLUID OR FUMES HAZARD

Toxic fluids or fumes can cause serious injury or death if splashed in the eyes or on skin, inhaled, or swallowed.

- Please pay attention to know the specific hazards of the fluids before spraying.
- Store hazardous fluid in approved containers, and dispose of it according to applicable guidelines.



PERSONAL PROTECTIVE EQUIPMENT

You must wear appropriate protective equipment when operating, servicing, or when in the operating area of the equipment to help protect you from serious injury, including eye injury, hearing loss, inhalation of toxic fumes, and burns. This equipment includes but is not limited to:

- Protective eyewear, and hearing protection.
- Respirators, protective clothing, and gloves as recommended by the fluid and solvent manufacturer.



Maintenance Tips:

1. There are two sides for the ball seat, both are chamfered, for one side worn, change to another side.

- 2. While changing the V-packings (both the upper and lower ones) for piston rod, please note that the convexity side shall be towards the piston rod, then using rubber hammer to hit the flat side of the V-packings to fit the piston rod.
- 3. While fastening the screws for the pump block, please do not fasten one screw to maximum and then fasten the other one, the correct action is to fasten one screw to 90% depth first and then fasten the other screw to maximum and later fasten the first screw to maximum.
- 4. There is one washing piece inside the pressure sensor, normally the washer won't be broken, but it can not be left out.
- 5. After changing the upper V-packings, the nut shall be fully tightened by using a bench clamp.
- 6. Before starting up a new airless piston pump, please double check the two screws for the pump block and make sure that they are fully fastened. Same checking after changing new V-packings. As the V-packings are made of high polymer material, after being stocked or used for some time, they could somehow expand.
- 7. It's critically important to turn on the PRIME VALVE before spraying or after changing the paint bucket, if air happens to enter into the piston pump system and you forget to turn on the PRIME VALVE before spraying, it will do big damage to the machine system itself, as the compression ratio for paint coatings and for air are different.
- 8. The positive pole and negative pole for the motor can not be connected reversely via the carbon brush, if connected reversely, then the motor will turn reversely, if the machine runs this way for some time, the motor will become demagnetized. (*For model X20 only)
- 9. If the V-packings are broken, then there will be paint coatings leakage, please change V-packings immediately, otherwise, the paint coatings may enter into the gear box to damage the whole gear box.
- 10. While turning the pressure knob to adjust pressure, please do not turn the knob too hard, as the electric parts inside the knob could be damaged due to too hard turning.
- 11. There is a micro switch in every airless pump with a mechanical pressure control system, and the fixing screw of the micro switch is set properly before shipment, please do not try to change the position of the fixing screw, otherwise, the micro switch may not work properly. (For X20 model only)
- 12. One quick tip to identify if the ball seat is good or not, after turning the PRIME VALVE back to spraying position, please open the front cover, if the connection rod stays on the upper position, then the ball inside the piston rod is somehow damaged, if the connection rod stays on the lower position, then the ball seat is somehow damaged.
- 13. If the airless piston pump is not fully cleaned after spraying, the drywall coatings may stop the pressure sensor from working properly, so the airless piston pump shall be fully cleaned after spraying.
- 14. If the fuse is burned due to over voltage, please check the capacitor first to see if it's in good condition, if yes, then please further check the bridge rectifier with a universal meter.
- 15. One quick tip to check the pressure control board for airless piston pumps with a mechanical pressure control system, first step is to turn on the PRIME VALVE, then stick to the micro switch with a screwdriver, if the machine could stop, means no problem for the pressure control board.
- 16. If the airless pump is equipped with manifold filter, then the filter shall be often cleaned after spraying, once per day is recommended, or at least once per week, if the filter is totally stuck by drywall coatings, then the electric board and pressure sensor could be burned, under this situation, fuse could not protect the electrical board and pressure sensor.
- 17. As a reminder, for big airless piston pump with big flow rate (mainly refers to X45 and X52/X52L), please do not use short high pressure hose like 3m or 5m, as it might cause serious motor damage. Clean the machine, parts every time after finished the paint work.
- 18. Tips need to be replaced after 4000 – 5000 m² depending on abrasiveness of paint.
- 19. The piston rod/V-packing and sintered carbide ball need to be replaced after about 200 hours spraying, especially when the pressure goes down, or difficult to draw in paint.
- 20. For the permanent magnet DC motor, the carbon brush needs to be replaced after 1500 hours, otherwise, the motor will be damaged.
- 21. Please check every part that has been screwed on the machine very tightly before using the machine.
- 22. If the machine needs to be stored over 10 days, do run the machine with lubricating oil thoroughly, for rust protection or anything stuck inside the pump. (check the details in CLEAN UP)
- 23. For the maintenance of the fluid pump, do strictly in accordance with the instructions, and screw tightly. (check the details in Service)
- 24. Please read the manual or contact the distributor if any problems with the machine, DO NOT take the machine to pieces without professional staff.

Component Identification FOR X51L





AIRLESS PAINT SPRAYER

1	Cart/ Hose with wrap rack	Carry machine and Stows paint hose. (DP637H)
2	Filter Housing (Manifold filter inside**)	Manifold filter will reduce the tip clogs and ensure you nice finish.
3	Digital pressure display (Under the cover)	X20 With Pressure Gauge Only X24 X28 X32 X42 X45 X51 X80L With digital pressure display
4	Pressure regulator	Adjust the pressure for different applications.
5	Prime/Spray valve.	<ul style="list-style-type: none">●In PRIME position (pointing down) directs fluid to prime tube.●In SPRAY position (pointing parallel) directs pressurized fluid to paint hose.●Automatically relieves pressure system in overpressure situations
6	Fluid pump (piston rod&v-packing** inside)	Drains fluid in system during priming and pressure relief.
7	Suction tube	Draws fluid from paint pail into pump. (the tube must be screwed tightly otherwise air enter inside, so the pressure can't be reached your desired high pressure.)
7	Suction hose*	The pics is X51L lower suction type, For X45, it will be the suction tube, and X20/24/28 will be the suction hose instead.
8	Suction filter	Suction filter reduce the tip clogs and ensure you nice finish.
9	Prime hose	
10	Power Plugs	It will be suitable for countries.
11	Wheel	Easy for machine to stand/move on the ground.
12	Airless spray gun	Dispenses fluid.
13	High pressure hose	Transports high-pressure fluid from pump to spray gun.

(The parts marked with ** are easily worn parts.)

Technical Data

Item No.	X20	X20i
Pressure controlling	Mechanical	Electronic
Motor power	1100W PMDC	1100W PMDC
Flow rate	2.0L/MIN	2.0L/MIN
Max. tip size	0.021"	0.021"
Max.Working pressure	200bar/2900psi	200bar/2900psi
PICS		
Contents in package	X-450 Gun, X 517 Spray Tip, X Guard, 1/4 in x 15M Airless Hose, 45cm extension pole, lubricating oil .	X-450 Gun, X 517 Spray Tip, X Guard, 1/4 in x 15M Airless Hose, 45cm extension pole, lubricating oil .
X24	X28	X32
Electronic	Electronic	Electronic
1500W Brushless Motor	1700W Brushless Motor	1800W Brushless Motor
2.4L/MIN	2.8L/MIN	3.2L/MIN
0.023"	0.025"	0.031"
210bar/3045psi	210bar/3045psi	210bar/3045psi
		
X-450 Gun, X 517 Spray Tip, X Guard, 1/4 in x 15M Airless Hose, 45cm extension pole, lubricating oil .	X-450 Gun, X 517 Spray Tip, X Guard, 1/4 in x 15M Airless Hose, 45cm extension pole, lubricating oil .	X-450 Gun, X 521 Spray Tip, X Guard, 1/4 in x 15M Airless Hose, 45cm extension pole, lubricating oil .

X42	X41L	X45
Electronic	Electronic	Electronic
2500W Brushless Motor	2600W Brushless Motor	2000W Brushless Motor
4.0L/MIN	4.0L/min	4.2L/MIN
0.035"	0.033"	0.033"
210bar/3045psi	210bar/3045psi	210bar/3045psi
		
X-450 Gun, X 527 Spray Tip, X Guard, 1/4 in x 15M Airless Hose, 45cm extension pole, lubricating oil .	X-450 Gun, X 525 Spray Tip, X Guard, 1/4 in x 15M Airless Hose, 45cm extension pole, lubricating oil .	X-450 Gun, X 525 Spray Tip, X Guard, 1/4 in x 15M Airless Hose, 45cm extension pole, lubricating oil .
X51L	X80	X81L
Electronic	Electronic	Electronic
3000W Brushless Motor	3000W Brushless Motor	3000W Brushless Motor
5.1L/MIN	8.0L/MIN	8.0L/MIN
0.037"	0.048"	0.045"
210bar/3045psi	210bar/3045psi	210bar/3045psi
		
DP-6376G High pressure spray gun, X 525+531 Spray Tip, X Guard, 1/4 in x 15M Airless Hose, 45cm extension pole, lubricating oil .	X-450 Gun, X 525&543 Spray Tip, X Guard, 3/8 in x 15M Airless Hose, 1/4"x1M whip hose, 3/8"x1/4" connector, 45cm extension pole, lubricating oil .	DP-6376G Gun, X 539 Spray Tip, X Guard, 3/8 in x 15M Airless Hose, 45cm extension pole, lubricating oil .

Operation

Trigger Lock

Always engage the trigger lock when you stop spraying to prevent the gun from being triggered accidentally by hand or if dropped or bumped.

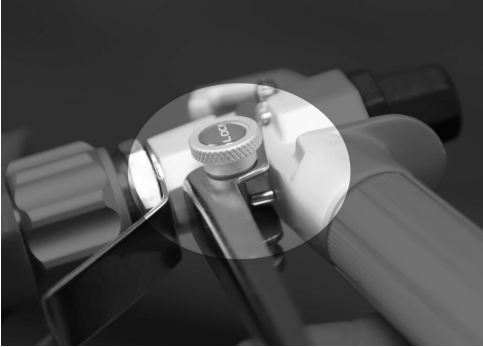

3. Hold gun firmly to side of pail.
Trigger the gun to relieve pressure.



Pressure Relief Procedure

Follow this **Pressure Relief Procedure** whenever you stop spraying and before cleaning, checking, servicing, or transporting equipment.

1. Turn power switch OFF and unplug power cord.



2. Turn Prime/Spray valve to PRIME to relieve pressure.

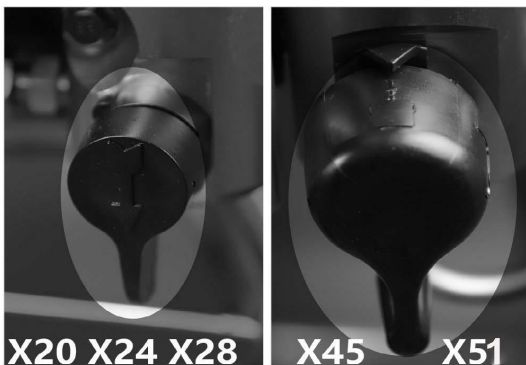

4. Engage trigger lock.

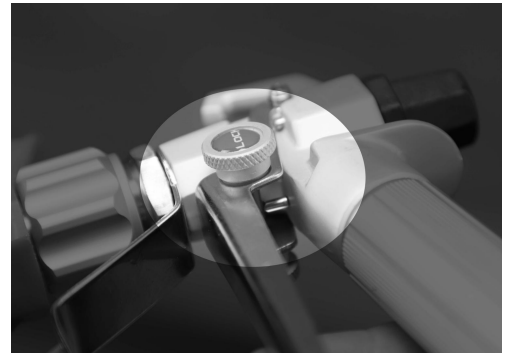

NOTE: Leave Prime/Spray valve in the PRIME position until you are ready to spray again.
If you suspect the spray tip or hose is clogged or that pressure has not been fully relieved after following the steps above, VERY SLOWLY loosen tip guard retaining nut or hose end coupling to relieve pressure gradually, then loosen completely. Clear hose or tip obstruction. Read Unclogging Spray Tip instructions in the Sprayer or Gun Operation manual.

Setup

1. Prepare the paint according to the manufacturer's recommendations

This is probably one of the most important steps toward trouble-free spraying!

Remove any skin that may have formed on the top of the paint. If necessary, thin the paint. Finally, strain the paint through a fine nylon mesh filter bag (available at most paint dealers) to remove particles that could clog the spray tip

3. Unscrew tip and guard assembly from gun.

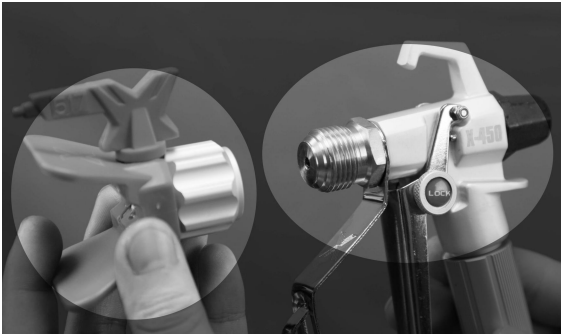

4. Uncoil hose and connect one end to gun. Use two wrenches to tighten securely and tightly.

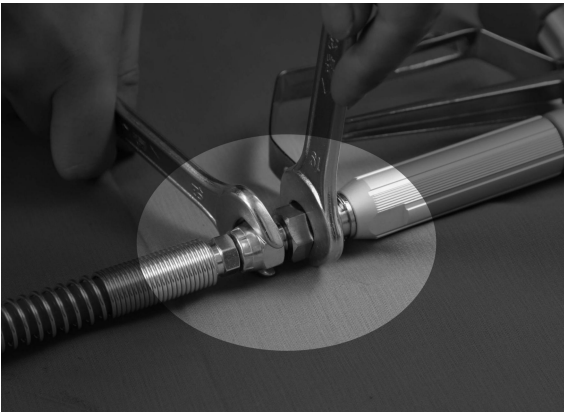

5. Connect other end of hose sprayer.

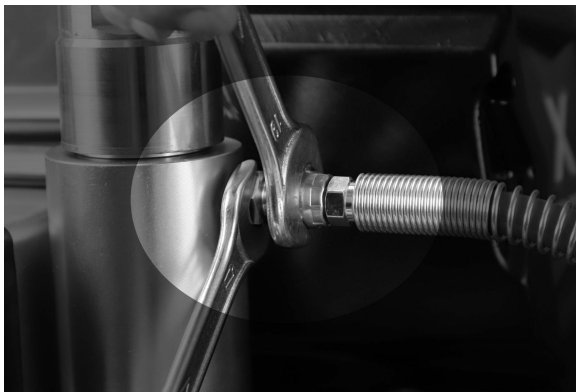

6. Oiling

Fill throat packing nut with lubricating oil(3~5 drops) to prevent premature packing wear, Do this every time when you spray.



7. Check the electrical service

Be sure the electrical outlet is properly grounded. Longer extension cords may affect the sprayer performance. Use more spray hose, not longer extension cords.

8. Plug in the sprayer.

First be sure the ON/OFF switch is OFF and the pressure control is turned fully counterclockwise. Plug the sprayer into a grounded outlet that is at least 3 m away from the spray area to reduce the chance of a spark igniting, spray vapors or dust particles.



Pressure regulator valve

Clockwise: stronger / Higher pressure



Counter clockwise: weaker / Lower pressure



Startup

1. First be sure the ON/OFF switch is OFF.
2. Adjust Pressure Control counter clockwise to lowest pressure.
3. Place the suction hose into the coating barrel.

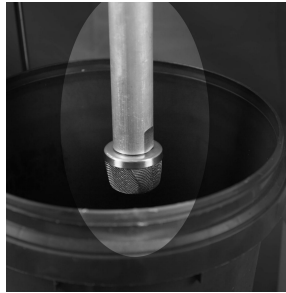

4. Pull up the Prime/Spray Valve to Prime position.

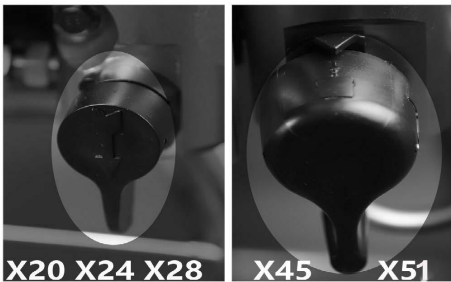

5. Plug sprayer in a grounded cable socket.
6. Switch ON the machine.



7. Turn the Pressure Control clockwise, till the fluid is circulating in the prime tube

8. Turn power switch OFF.



9. Transfer suction tube to paint pail and submerge suction tube in paint.

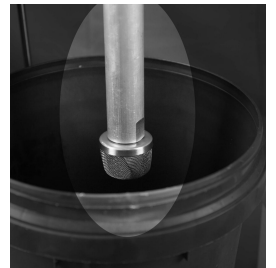

10. Turn power switch ON.

11. When you see paint coming out of prime tube:

- (1). Point gun into waste pail.
- (2). Unlock gun trigger lock.
- (3). Pull and hold gun trigger.
- (4). Turn Prime/Spray valve to SPRAY position.

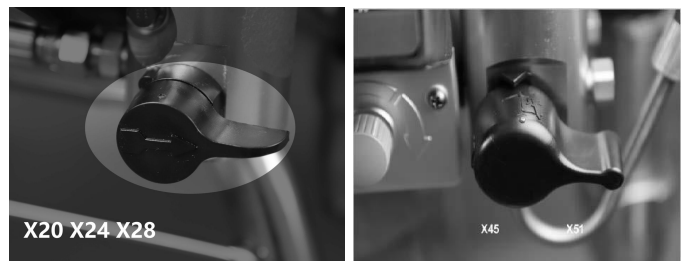

12. Continue to trigger gun into waste pail until you see only paint coming out of gun.

13. Release trigger. Engage trigger lock.

14. Transfer prime tube to paint pail and clip prime tube to suction tube.

SPRAYING

SPRAYING TECHNIQUE

1. The key to a good paint job is an even coating over the entire surface. With spray painting, this is done by using even strokes, with your arm moving at a constant speed and keeping the spray gun a constant distance from the surface.

2. As much as possible, keep the spray gun at right angles to the surface. This means moving your entire arm back and forth rather than just flexing your wrist.

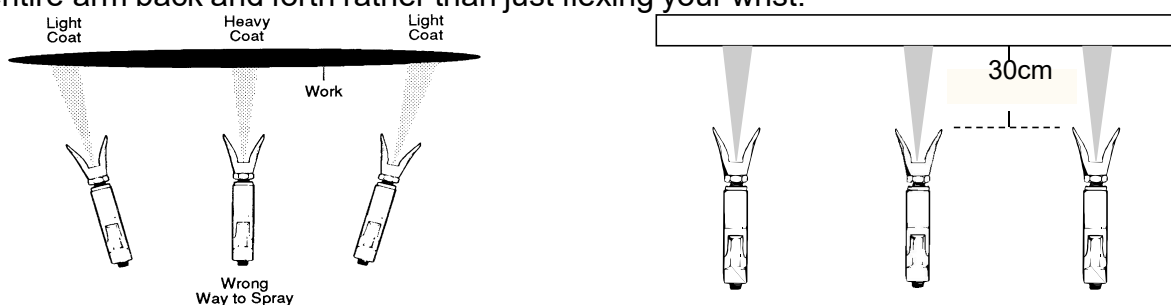

3. Keep the spray gun perpendicular to the surface, otherwise one end of the pattern will be thicker than the other.

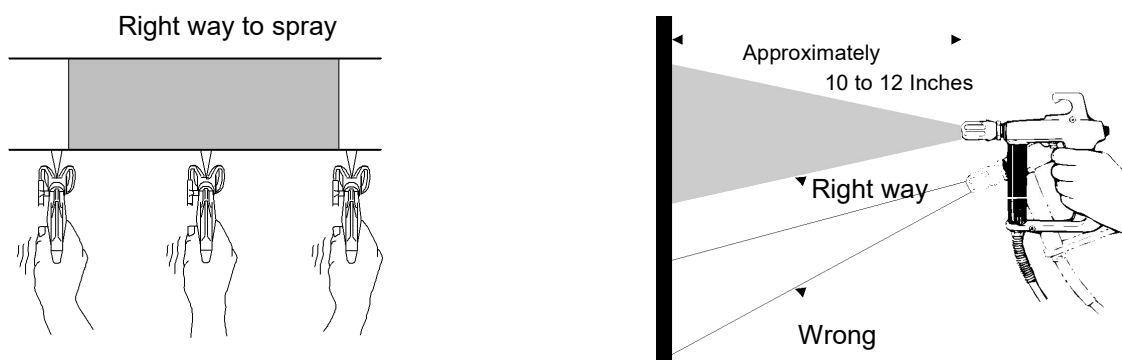

4. In most cases, the best spraying distance is 10 to 12 inches (25-30cm) between the spray tip and the surface.

5. The spray gun should be triggered off at the end of each stroke and on again at the beginning of the next. This avoids paint buildup at the end of the stroke which may result in runs and sags. Triggering at the end of the stroke also saves paint and results in a better looking job. (See picture below)

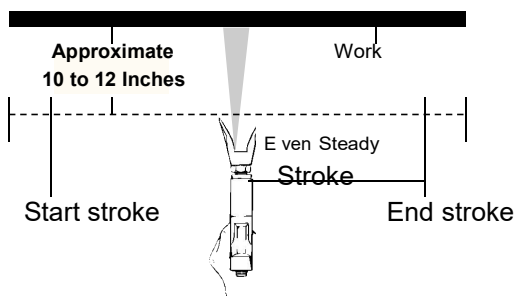

6. The correct speed for moving the gun will allow a full, wet coating to be applied without runs or sags. Lapping each stroke about 40% over the previous stroke produces uniform paint thickness. Spraying in a uniform pattern alternately from right to left and then left to right, provides a professional finish. (See picture on the right)

One way to do this is to point the spray tip at the edge of the last stroke

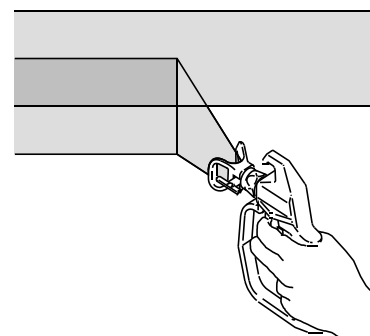

before triggering the gun on.

7. When taking a short break from painting (up to 1 hr.), lock the spray gun trigger **OFF**, reduce pressure to its minimum (zero) setting and set the unit to Prime position . Turn sprayer off and unplug. Refer to Pressure Relief Procedure.

8. For interior corners, such as on a bookcase or inside a cabinet, aim the gun toward the center of the corner to spray. By dividing the spray pattern this way, the edges on both sides are sprayed evenly.

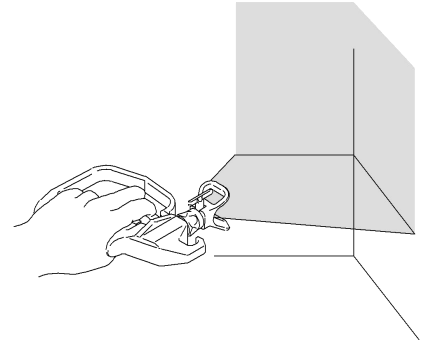

Install Tip & Guard on Spray Gun

1. Engage trigger lock.

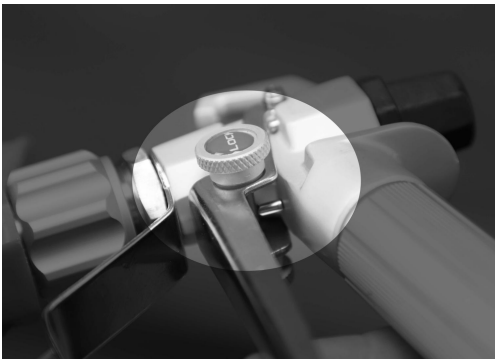

2. Verify tip and guard parts are assembled in order shown.

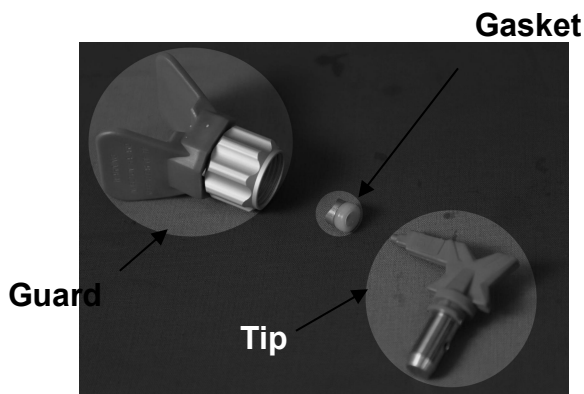

3. Use tip to align seat

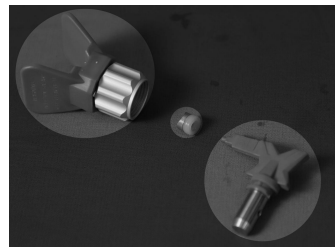

Tip must be pushed in guard all the way into guard

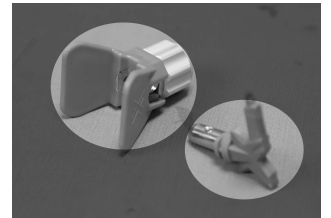

4. Screw tip and guard assembly on gun. Tighten retaining nut.

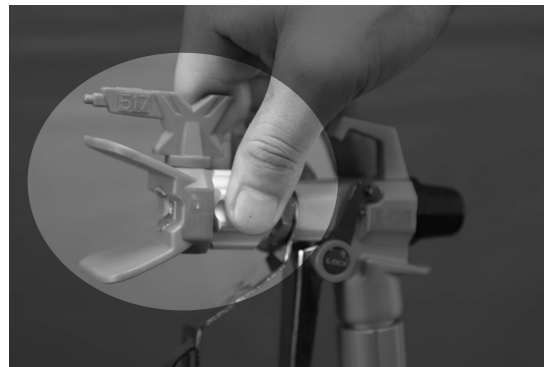



Tip Selection

Selecting Tip Hole Size

Tips come in a variety of hole sizes for spraying a range of fluids. Your sprayer includes an 0.017 in (0.43 mm) tip or maybe 0.019" (0.48mm) for use in most spraying applications. For narrow or smaller surfaces(cabinet,fence,railings), pattern width of 6 inches is the best choice, it will provide sharper definition and more control; For large surfaces(Ceilings/walls), a wider spray pattern width of 10 to 12 inches is your best choice to cover large areas more quickly.

Using a good-quality spray tip that is appropriately sized for your painting project is critical to achieving good spraying results, the spray tip controls the amount of paint applied and the area the spray pattern will cover. A range of tip sizes classified by both hole size and spray pattern width can be used, based on 3 factors;

1;Coating/painting 2;Surface being sprayed 3;Sprayer's ability to support the tip hole size.

A key difference is sprayers is the maximum tip they can support. Choose your sprayer based on the coating types you'll be spraying, and make sure the largest tip(hole size) you plan to use is within the maximum tip size range the sprayer can support.

It is always best to have a machine with more capacity, Fox example, if you plan to use .017 tip frequently, your sprayer's capacity should be one tip hole size larger(.019 tip), this allows for tip wear, which causes the tip hose size to increase.

Choosing the Correct Tip

Consider coating and surface to be sprayed. Make sure you use best tip hole size for that coating and best fan width for that surface.

Tip Hole Size

Tip hole size controls flow rate - the amount of paint that comes out of the gun.

HINTS:

- Use larger tip hole sizes with thicker coatings and smaller tip hole sizes with thinner coatings.

Fan Width Fan width is the size of the spray pattern, which determines the area covered with each stroke. Narrower fans deliver a thicker coat, and wider fans deliver a thinner coat.

Tip Hole Size	Coatings				
	<i>Stains</i>	<i>Enamels</i>	<i>Primers</i>	<i>Interior Paints</i>	<i>Exterior Paints</i>
0.011 in. (0.28 mm)	✓				
0.013 in. (0.33 mm)	✓	✓			
0.015 in. (0.38 mm)		✓	✓	✓	
0.017 in. (0.43 mm)			✓	✓	✓
0.019 in. (0.48 mm)					✓

Understanding Tip Number

The last three digits of tip number contain information about hole size and fan width on surface when gun is held 12 in. (30.5 cm) from surface being sprayed.

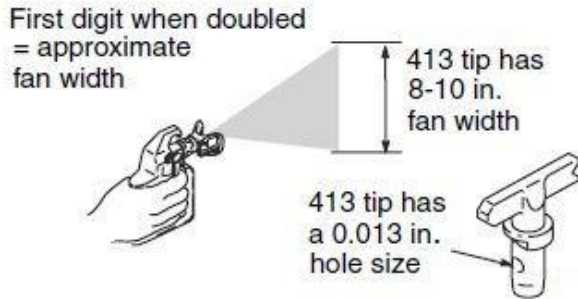

Last two digits = tip hole size in thousands of an inch

Tip Part No.	Fan Width 12 in. (305 mm) from surface	Hole Size
311	6 - 8 in. (152 - 203 mm)	0.011 in. (0.28 mm)
411	8 - 10 in. (203 - 254 mm)	0.011 in. (0.28 mm)
313	6 - 8 in. (152 - 203 mm)	0.013 in. (0.33 mm)
413	8 - 10 in. (203 - 254 mm)	0.013 in. (0.33 mm)
415	8 - 10 in. (203 - 254 mm)	0.015 in. (0.38 mm)
515	10 - 12 in. (254 - 305 mm)	0.015 in. (0.38 mm)
417	8 - 10 in. (203 - 254 mm)	0.017 in. (0.43 mm)
517	10 - 12 in. (254 - 305 mm)	0.017 in. (0.43 mm)

Reversible Tip Selection Chart

Orifice Size	Fan Width - Inches					Flow Rate		Application	Filter
	4" - 6" Fan	6" - 8" Fan	8" - 10" Fan	10" - 12" Fan	12" - 14" Fan	gpm	L/min		
0.011"	211	311	411	511	611	0.12	0.45	Stain or Lacquer	150mesh (red)
0.013"	213	313	413	513	613	0.18	0.68		
0.015"	215	315	415	515	615	0.24	0.91	Oil Base Paint	100mesh (yellow)
0.017"	217	317	417	517	617	0.31	1.17	Latex Paint / Acrylic / Enamel	100mesh
0.019"	219	319	419	519	619	0.38	1.44		60mesh (white)
0.021"		321	421	521	621	0.47	1.78	Heavy latex	60mesh (white)
0.023"		323	423	523	623	0.57	2.16		
0.025"		325	425	525	625	0.67	2.54		
0.027"			427	527	627	0.77	2.91		
0.029"		329	429	529	629	0.90	3.41	Elastomeric / Blockfiller / Primer /	30mesh (green)
0.031"		331	431	531	631	1.03	3.90		
0.033"		333	433	533	633	1.17	4.43		
0.035"		335		535		1.31	4.98		
0.043"	243	343	443	543	643	1.98	7.51		

Important things to know about tip wear

It's important to replace a tip when it becomes worn, this ensures you'll have a precise spray pattern, maximum productivity and a quality finish. When tip wears, the hole (orifice) size increases and spray pattern width decreases.

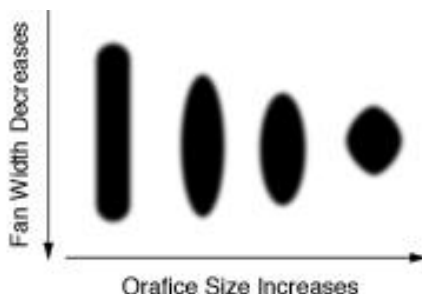

Tip life varies by coating, Extend tip life by spraying at the lowest pressure that breaks up (atomizes) the coating into a complete spray pattern.

Recommend tip replacement Latex: After 4000~5000 m²

CLEAN UP

As with all spray equipment, your sprayer must be cleaned properly or it will not operate properly. Clogged are the most common causes of problems. If followed, these guidelines will insure trouble free performance from your sprayer.

1. Do pressure relief procedure.

Remove siphon tube set from paint and place in flushing fluid.

Note: Use water for water base paint and mineral spirits for oil base paint

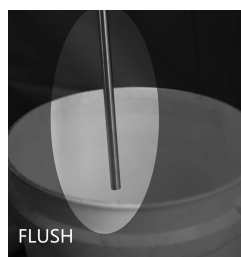

2. Turn power On, turn prime/spray valve up to close drain valve.



3. Increase the pressure to about 1/2 maximum take the trigger safety OFF, trigger gun until flushing fluid appears.



3. Move the gun to waste pail, hold gun against pail, trigger gun to thoroughly flush system, release trigger and put trigger safety ON.



4. Turn prime valve down to open drain valve and allow flushing fluid to circulate for 15 seconds to clean drain tube.

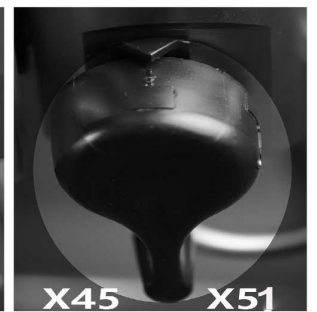

5. Raise siphon tube above flushing fluid and run sprayer for 15 or 30 seconds to drain fluid.

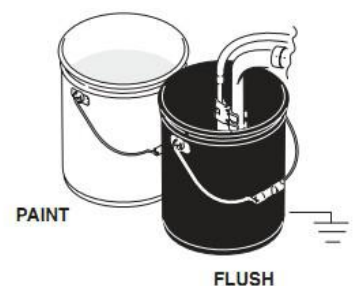

7. Turn up prime valve up to close drain valve, Trigger gun into flushing pail to purge fluid from hose, Turn Power **OFF**.

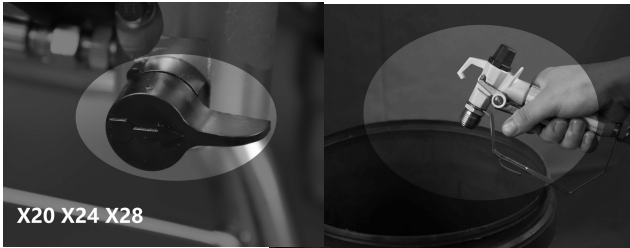

8. Turn prime valve down to open drain valve, Unplug sprayer.

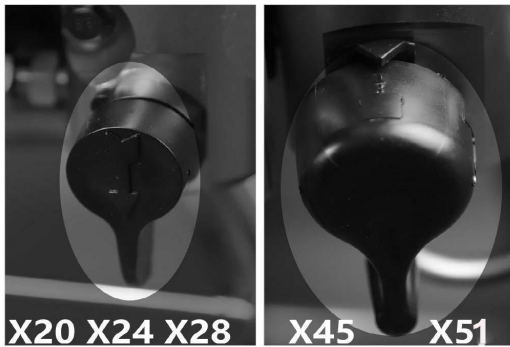

9. Remove filters from gun and sprayer, if installed. Clean and inspect, install filters.



10. If flushing with water, flush again with mineral spirits, or pump armor, to leave a protective coating to prevent freezing or corrosion.

11. If the machine will be storage for over 10 days, after you cleaned the machine thoroughly, please take off the suction tube, hose&gun, and pour about 10ml WHITE lubricating oil into the fluid pump, Then switch on the machine and let it keep running (PRIME POSITION) for 5 seconds(once you can see the oil in the prime tube), This will prevent the wet parts inside being stuck, corrosive or rusted.

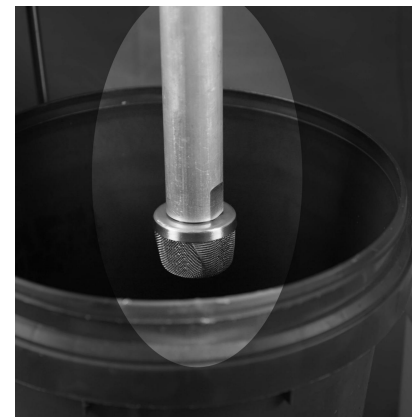

12. Wipe sprayer, hose and gun with a rag soaked in water or mineral spirits.





Troubleshooting

Problem	Cause	Solution
Power switch is on and sprayer is plugged in, but motor does not run, and pump does not cycle.	Pressure is set at zero pressure.	Turn pressure control knob clockwise to increase pressure setting.
	Motor or control is damaged.	Please contact with your supplier or DPAIRLESS directly.
	Electric outlet is not providing power.	<ul style="list-style-type: none">• Try a different outlet or plug in something that you know is working to test outlet.• Reset building circuit breaker or replace fuse.
	Extension cord is damaged.	Replace extension cord.
	Sprayer electric cord is damaged.	Check for broken insulation or wires. Replace electric cord if damaged.
	Paint and/or water is frozen or hardened in pump.	<p>Unplug sprayer from outlet. If frozen do NOT try to start sprayer until it is completely thawed or you may damage the motor, control board and/or drivetrain.</p> <p>Make sure power switch is OFF. Place sprayer in a warm area for several hours. Then plug in power cord and turn sprayer ON. Slowly increase pressure setting to see if motor will start.</p> <p>If paint is hardened in sprayer, pump packings, valves, drivetrain or pressure switch may need to be replaced. Please contact with your supplier or contact with DP-AIRLESS directly.</p>



AIRLESS PAINT SPRAYER

Problem	Cause	Solution
Sprayer starts up but does not draw in paint.	Unit will not prime or has lost prime	Replace prime Unit
	No paint. Suction tube not totally immersed in paint	Immerse suction tube in paint
	Suction set filter clogged.	Clean filter.
	Suction tube loose at inlet valve	Clean connection and tighten
	Inlet valve is leaking	Clean inlet valve. Be sure the ball seat is not nicked or worn and that ball seats well, Reassemble valve.
	Pump packing are worn	Replace pump packings.
	Piston rod worn or damaged.	Clean or replace
Pump cycles but does not build up pressure.	Pump is not primed.	Prime pump.
	Inlet screen is clogged .	Clean debris off inlet screen and make sure suction tube is immersed in fluid.
	Suction tube is not immersed in paint.	Make sure suction tube is immersed in paint.
	Suction tube is leaking.	Tighten suction tube connection. Inspect for cracks or vacuum leaks. If cracked or damaged, replace suction tube.
	Prime/Spray Valve is worn or obstructed with debris.	Clean the valve or replace a new one.
Pump cycles, but paint only dribbles or spurts when spray gun is triggered.	Pressure is set too low.	Slowly turn Pressure Control Knob clockwise to increase pressure setting which will turn motor on to build pressure.
	O-ring in pump is worn or damaged	Replace O-rings
	Inlet valve ball is packed with material	Clean inlet valve,
	Spray tip is clogged	Unclog spray tip
	Fluid filter is clogged.	Clean or replace fluid filter
	Spray gun fluid filter is clogged.	Clean or replace gun fluid filter,
	Spray tip is too large or worn.	Replace tip.



AIRLESS PAINT SPRAYER

Problem	Cause	Solution
Sprayer draws up paint but drops away when gun is opened	Worn spray tip	Replace with new tip.
	Suction set filter clogged	Clean filter.
	Gun or spray tip filter plugged.	Clean or replace filter. Keep extra filters on hand
	Paint too heavy or coarse.	Thin or strain paint
	Worn V-packing assembly.	Replace
	Inlet valve worn or damaged.	Replace valve
Tip assembly leaks	Assembled incorrectly	Check assembly.
	Worn seal.	Replace seal.
Spray gun won't spray	Spray tip, gun filter or tip clogged	Clean spray tip
	filter plugged	Clean or replace gun or filter.
	Spray tip in Clean position	Put tip in Spray position
Paint tailing.	Pressure is set too low.	Increase pressure
	Gun, tip, or suction filter plugged.	Clean filters
	Suction tube loose	Tighten suction tube fitting
	Tip worn.	Replace tip
	Paint too thick	Thin paint
Thermal overload tripped	Motor over heated.	Allow to cool 15 to 30 min.
	Paint build up on motor.	Clean paint from motor.
	Unit sitting in hot sun.	Move to a shady location
No display, sprayer operates.	Display is damaged or had bad connection.	Check connection, replace display
Display error code E4	<p>Description:Over-current protection for the electronical control board</p> <p>Possible Reason:</p> <ol style="list-style-type: none"> 1.To low voltage, too long cable length, bad contact of the patch board. 2.Using too small tip size. 3.Coatings is too thick. 4.Pressure sensor is damaged, too 	<ol style="list-style-type: none"> 1.Check if the voltage reaches 220V, check if the cable length is too small, check if the patch board is properly connected. 2.Change bigger tip size. 3.Thin the coatings as per instruction. 4.Change the pressure sensor. 5.Change the electronical control board.



AIRLESS PAINT SPRAYER

	<p>high working pressure will cause automatic projection.</p> <p>5. Electronical control board is broken.</p>	
Display error code E3	<p>Description: Pressure sensor is damaged.</p> <p>Possible Reason: Inner parts of the pressure sensor is broken.</p>	<p>Change a new pressure sensor.</p> <p>Friendly Reminder: Please thoroughly clean the machine in time each time after spraying, keep the inner fluid pump clean, and please store the machine indoors in winter time.</p>
Display error code E5	<p>Description: Over-heat protection for the electronical control board</p> <p>Possible Reason: Over-heat on the electronical control board, the most likely reason is using too small tip size.</p>	<p>Turn off the power, wait till the electronical control board cools down, and change bigger tip size.</p>
Display error code E12	<p>Description: no-load protection</p> <p>Possible Reason: coatings in the bucket is empty, the machine will automatically stop running to protect the V-packings from fast wear-out.</p>	<p>Turn off the power and then turn on the power, or turn the pressure regulator to minimum and then reset the pressure.</p>
Display error code E14	<p>Description: Motor block protection</p> <p>Possible Reason:</p> <ol style="list-style-type: none"> 1. Too low voltage and using too small tip size at the same time. 2. Inner parts of the fluid pump is damaged. 	<ol style="list-style-type: none"> 1. Check the voltage and change bigger tip size. 2. Check if the inner parts of fluid pump is damaged, if yes, change the fluid pump.
Display error code E15	<p>Description: Communication error of the electronical control board.</p> <p>Possible Reason: Static electricity interferes the communication inside the electronical control board.</p>	<p>Turn off the power, after the display screen is completely off, turn on the power, if it still can not solve the problem, then change a new electronical control board.</p>
Display error code (???)u	<p>Alarm for checking the power voltage</p> <p>Possible Reason: When the voltage is too low or the machine is not running smoothly, this error code will occur due to not enough input power supply.</p>	<ol style="list-style-type: none"> 1. Check the power cable, check if the patch board is loosened. 2. Change bigger tip size and retry. 3. Turn off the power and adjust the pressure regulator to minimum, after the display screen is completely off, turn on the power supply.
Paint leaks down outside of pump..	<p>Pump packings are worn</p>	<p>Replace pump packings.</p>



AIRLESS PAINT SPRAYER

<p>Fan pattern varies dramatically while spraying. OR Sprayer does not turn on promptly when resuming spraying.</p>	<p>Pressure control switch is worn and causing excessive pressure variation.</p>	<p>Please contact with your supplier or DP-AIRLESS.</p>
---	--	---